

# Storeganizer sunumu

An isometric illustration of a warehouse interior. The scene is filled with various storage systems. On the left, there are tall metal pallet racks with multiple levels, each holding several wooden pallets stacked with cardboard boxes. Below the pallet racks, there are blue shelving units with many small compartments, some containing tools or small parts. A worker in red overalls is standing next to these shelves, reaching into one of the compartments. In the center, there are more stacks of cardboard boxes on pallets. A worker in red overalls is walking towards the right, carrying a box. In the background, a forklift is visible, and another worker is pushing a pallet jack with a load of boxes. The floor is light-colored with yellow safety lines. The overall scene depicts a well-organized and efficient storage environment.

# Our company

**2012**

Year founded

**115**

Satisfied customers

**> 300 %**

Compound annual growth rate (CAGR)

**13**

Countries

**2013**

Capital entry of conTeyor

# (Almost) Global presence

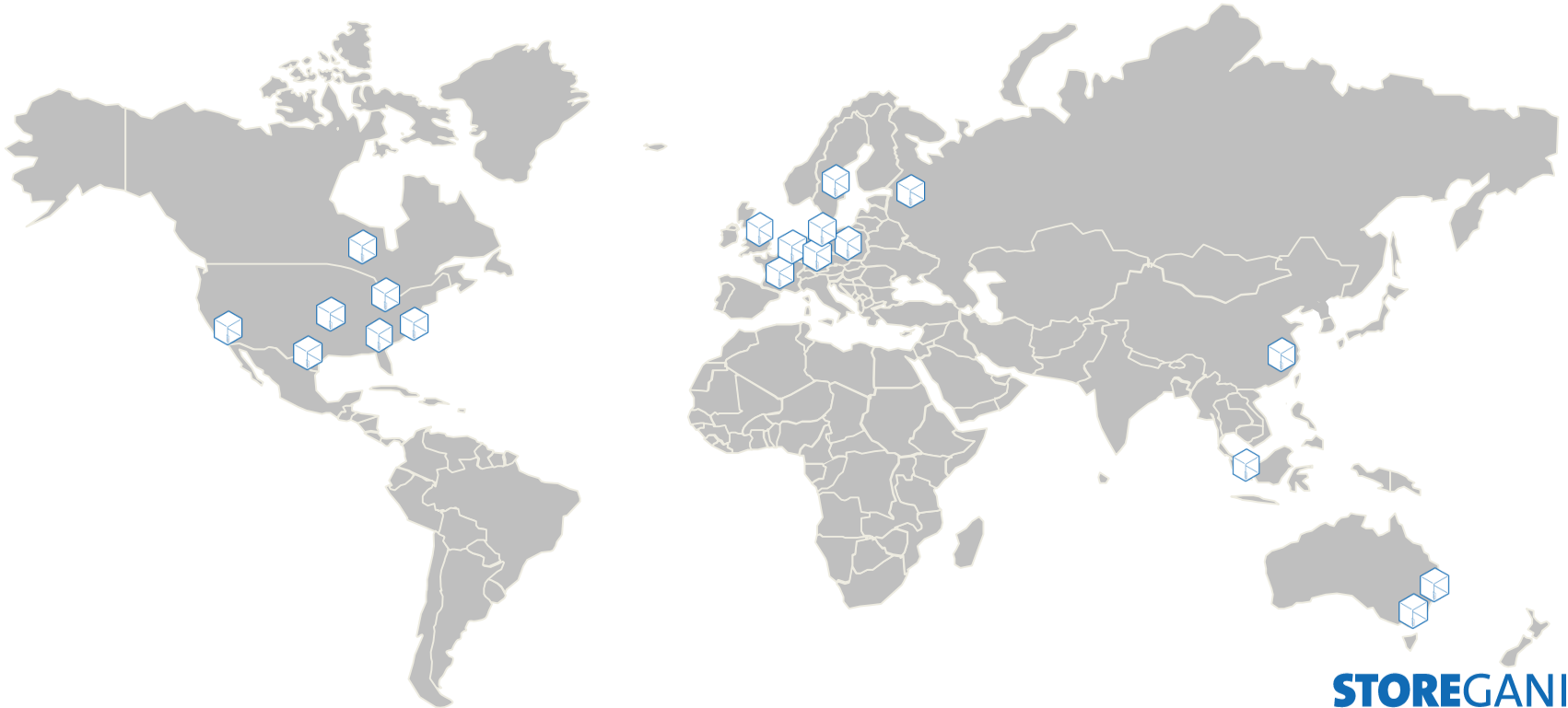

# conTeyor's core business: Supply Chain Systems



## Returnable Packaging

- Automotive
- Assembly (aerospace, electronics, ...)



## Warehousing

- 3PL
- e-commerce
- Distribution



## Logistics Systems

- Automotive
- Assembly
- Transport

# Core competence: Cube Utilisation

**Supply chain:** *the sequence of activities that take a product from a raw material to a consumable good*

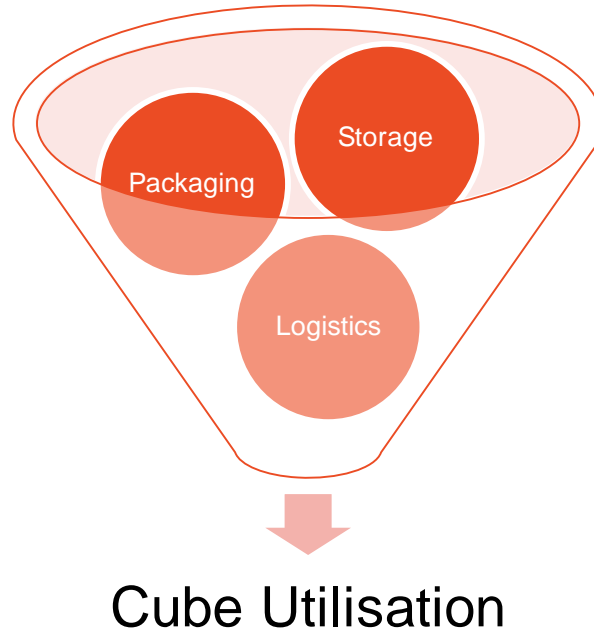

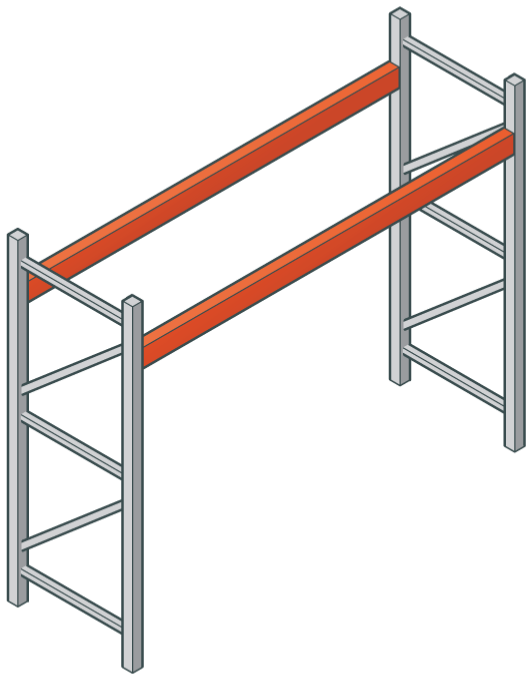

**Why do you need to  
maximize the ROI  
of your rack space?**

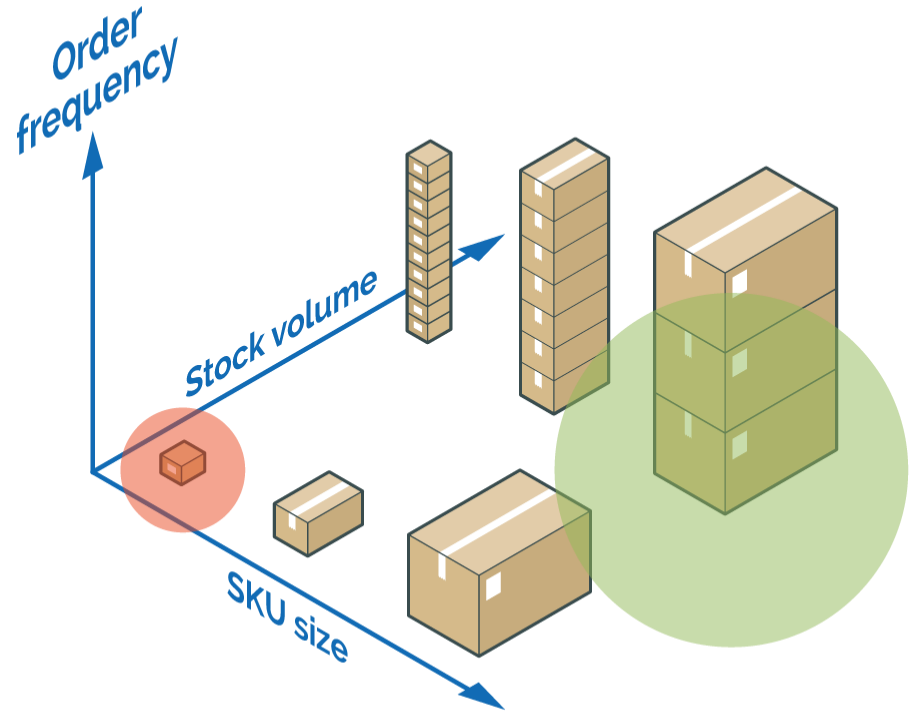
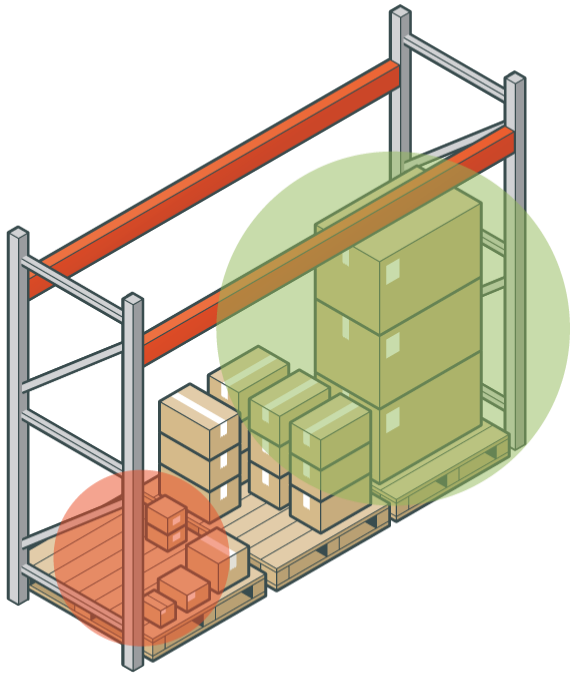

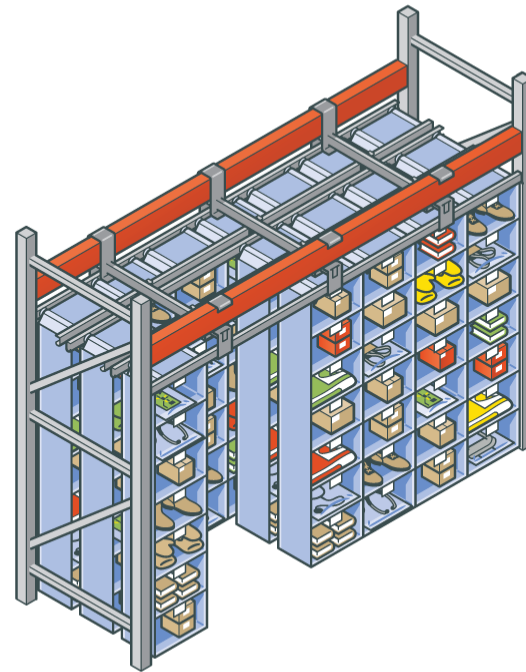
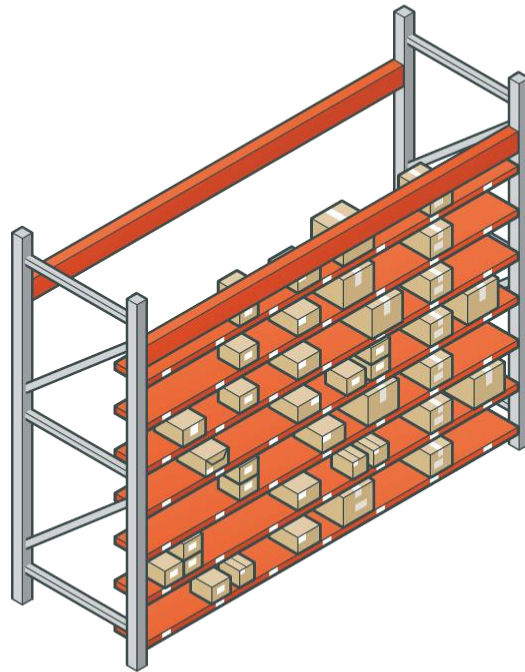
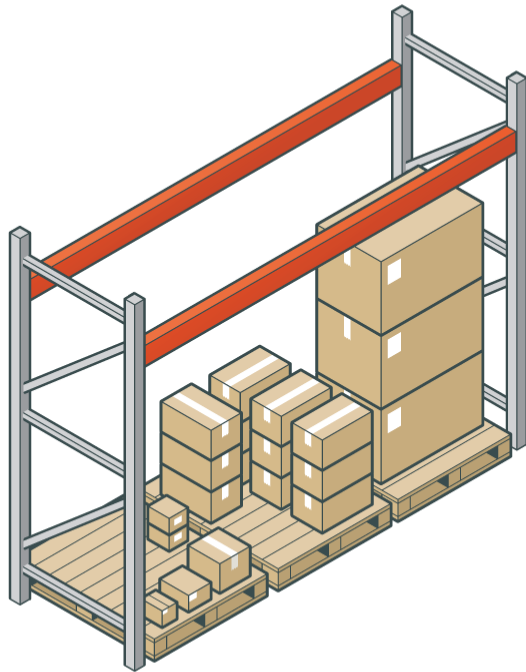



**42**  
locations

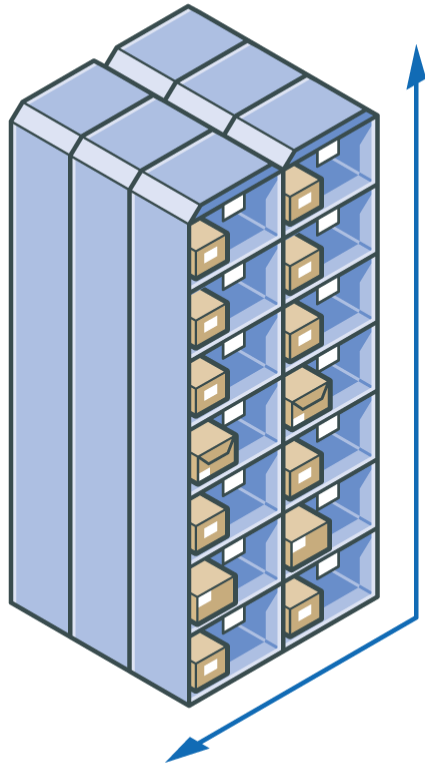

**3**  
locations

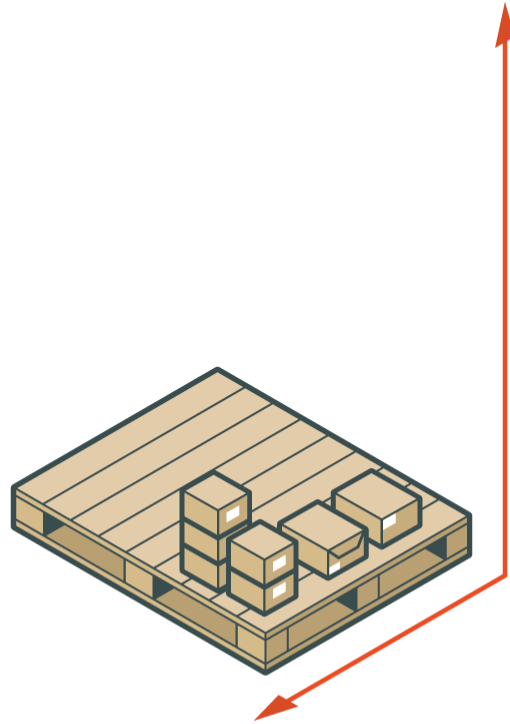

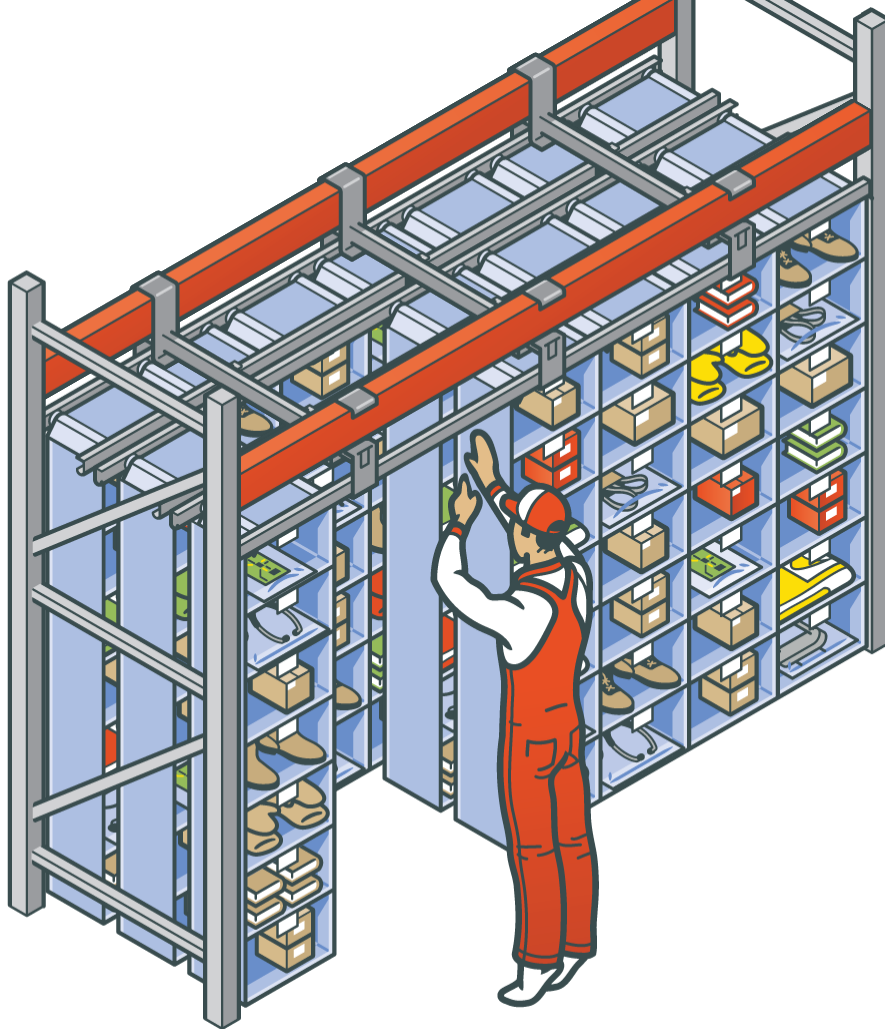

**STOREGANIZER**  
MORE STORAGE IN LESS SPACE

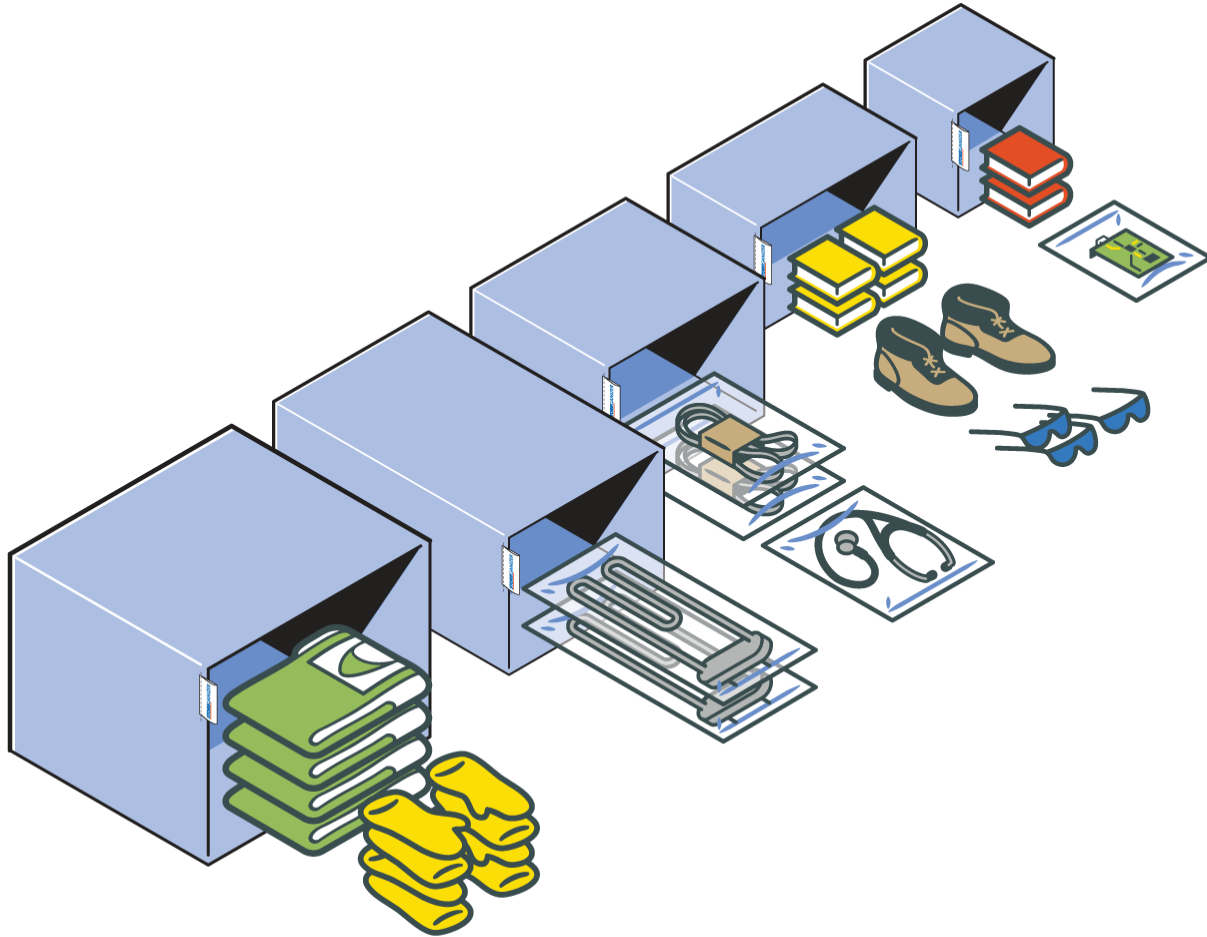

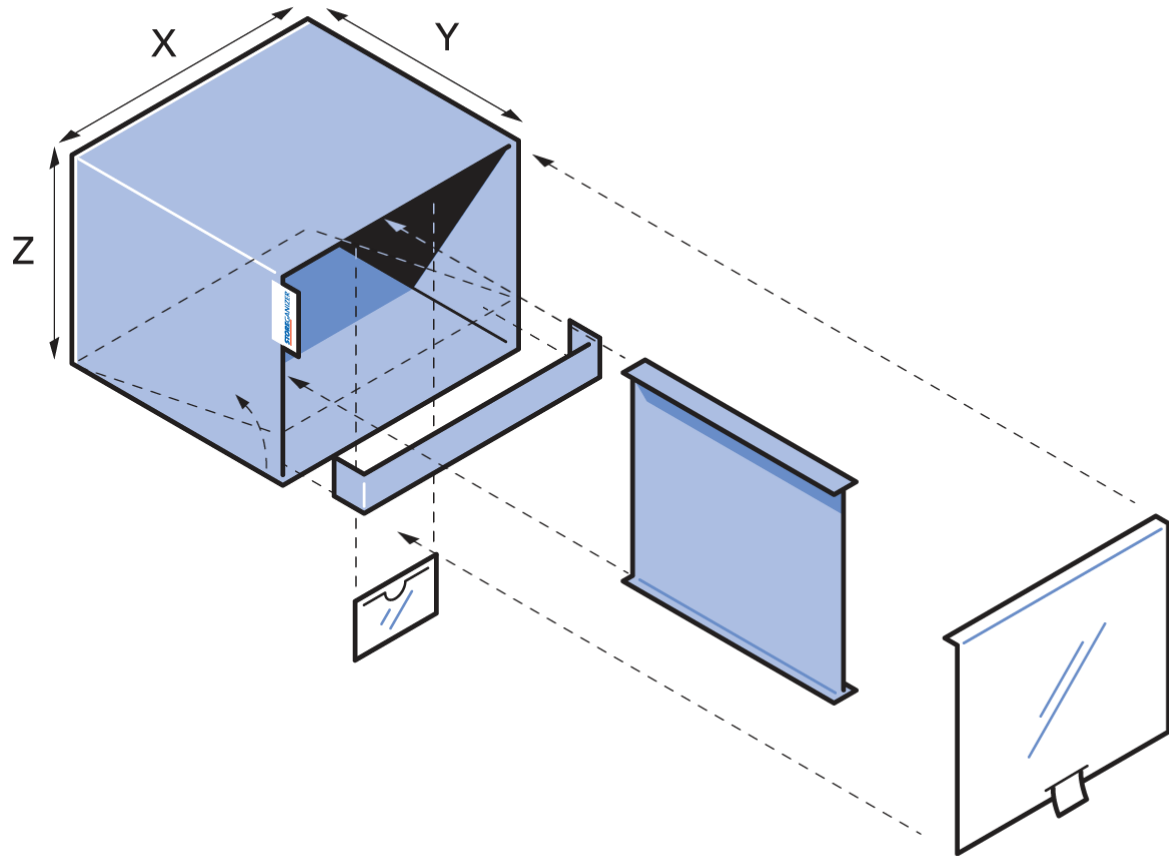

**STOREGANIZER**  
MORE STORAGE IN LESS SPACE

**STOREGANIZER**  
MORE STORAGE IN LESS SPACE

An isometric illustration of a warehouse. On the left, a worker in red overalls is organizing a blue shelving unit labeled 'LIMIT'. In the center, a worker in red overalls carries a box. On the right, a worker in red overalls pushes a pallet jack. A forklift is visible in the background. The warehouse is filled with stacks of cardboard boxes on pallets and shelves. The text 'Why Storeganizer?' is overlaid in the center in a large, bold, blue font.

# Why Storeganizer?

SPACE-SAVING  
MODULAR  
EFFICIENT  
ERGONOMIC  
CUSTOM-FIT  
TEXTILES  
POCKETS

S  
L  
I  
M

F  
I  
T

Innovative, high-density storage system providing a slim fit for all your small slow movers.



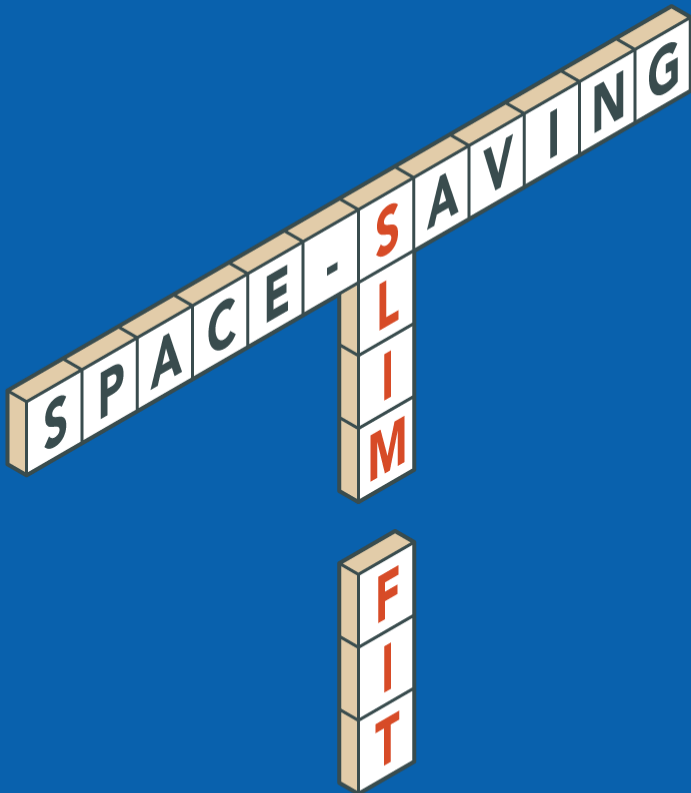

**+40%**  
usable storage space

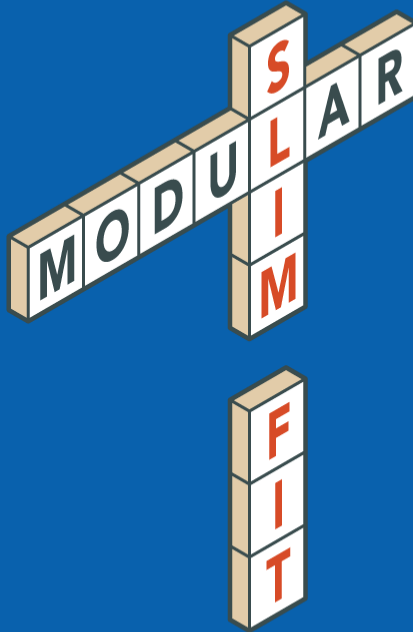

# Anywhere Any rack

Universal hanging system allows easy installation in any existing rack, where-ever needed in your warehouse.

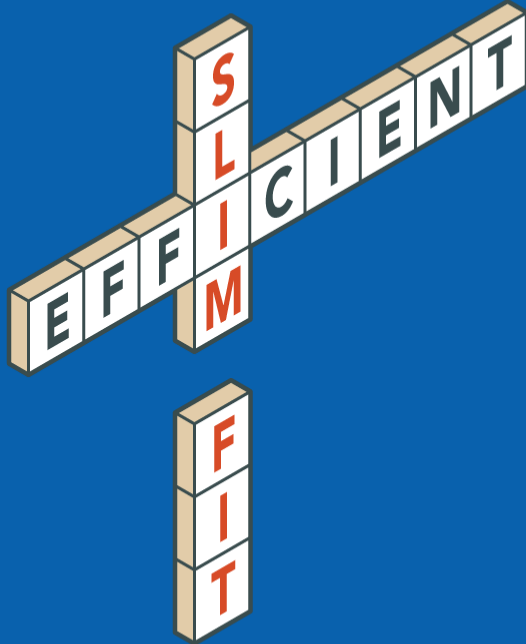

**+26%**

in order picking efficiency

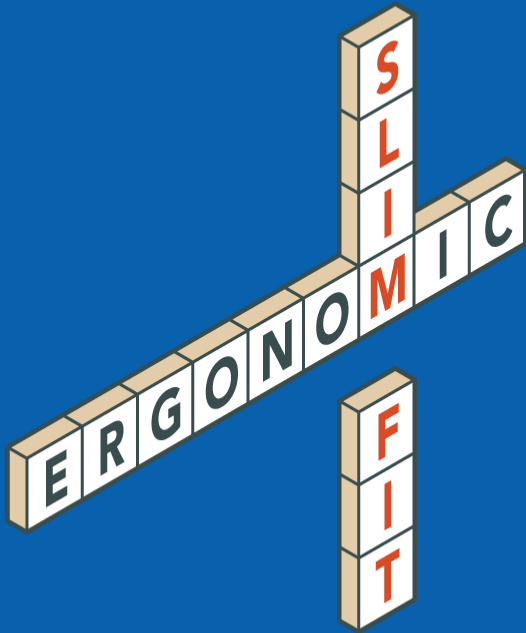

## Optimal picking, less bending/lifting

Stacked up to three rows deep, sliding left/right on rollers for easy access to pockets in the back.

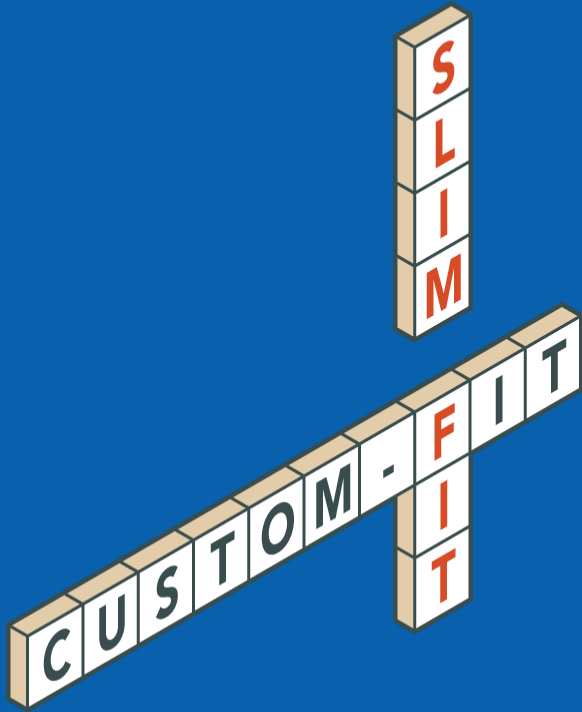

# Tailor-made for your inventory needs

Open sizes and specifications

– not limited to pre-set standard ranges.

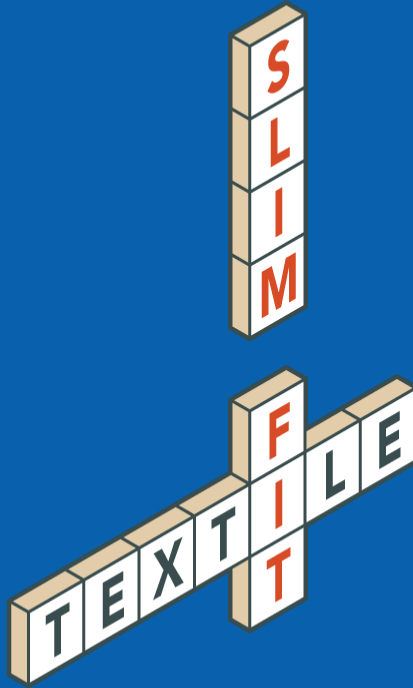

# Industrial fabric

cost-efficient, environmentally sound, highly protective.

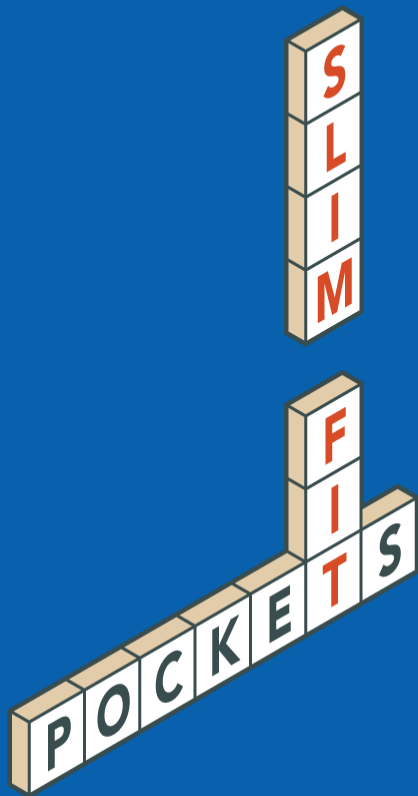

# Storing small items on shelves wastes space

Storeganizer packs them more densely in vertical columns of slim pockets for greater space savings and faster picking.

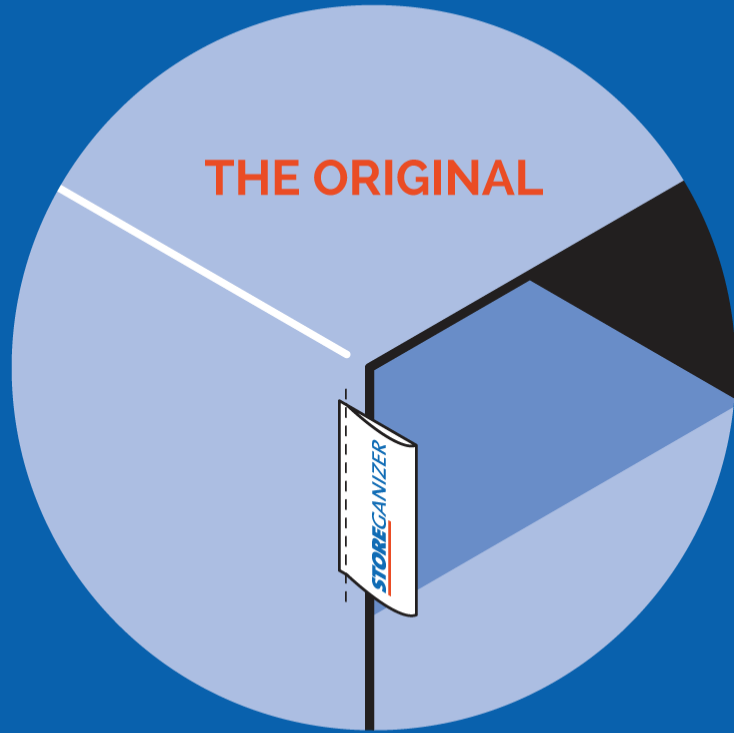

THE ORIGINAL

STOREGANIZER



An isometric illustration of a warehouse. On the left, a worker in red overalls is organizing a blue shelving unit labeled 'SLIMIT'. The rest of the warehouse is filled with tall metal racks holding numerous cardboard boxes on pallets. A worker is walking with a box, and a forklift is visible in the background. The word 'References' is centered in a large blue font.

# References



# ID Logistics accommodates additional product line thanks to Storeganizer

“There is simply no other solution that is able to **optimise small SKU storage to the same extent**”

**Jérôme Mellerin**  
Site Manager at ID Logistics Paris

# Teaming warehouse achieves 80% space savings with Storeganizer

“Rarely do you achieve a ‘win-win’ with new products. In this case, there are no disadvantages. These columns increase efficiency, eliminate expensive rack upgrades, site expansion or offsite leases, improve tidiness, lower staff stress and impress corporate leadership. **We only wish we had discovered it earlier.**”

**Todd Bayless**  
Material Services Team Lead at Rittal



**STOREGANIZER**  
MORE STORAGE IN LESS SPACE



# Gates optimizes idle warehouse space with Storeganizer

“Compared with our previous system, we save **no less than 90%** of the space in square and cubic metres with densely packed Storeganizer columns.”

**Hilde De Meyer**  
System Administrator at Gates

**STOREGANIZER**  
MORE STORAGE IN LESS SPACE



# Increased capacity and efficiency at H. Essers thanks to Storeganizer.

“I had no clue that such an efficient system to create supplementary stock room existed, offering a fitting degree of flexibility as well. We were able to continue our business operations as usual, our employees did not need to make any adaptations. **Everyone is very pleased about it.**”

**Carlo Theunissen**  
Business Unit Manager H.Essers

**STOREGANIZER**  
MORE STORAGE IN LESS SPACE



# Ceva Logistics Barton goes from 3 to 1 warehouse with Storeganizer

- Storage of aviation spare parts
- 210 racks
- More than 20.000 pick faces

# Other references



An isometric illustration of a warehouse. On the left, a worker in red overalls is organizing a blue shelving unit labeled 'LIMIT'. In the center, a worker in red overalls carries a box towards a forklift. On the right, another worker in red overalls pushes a hand truck. The warehouse is filled with various storage racks, including high industrial shelving and pallet racks, all containing stacks of cardboard boxes. A yellow floor line is visible.

# Questions?